

CGL-120HP DC Motor Pumps

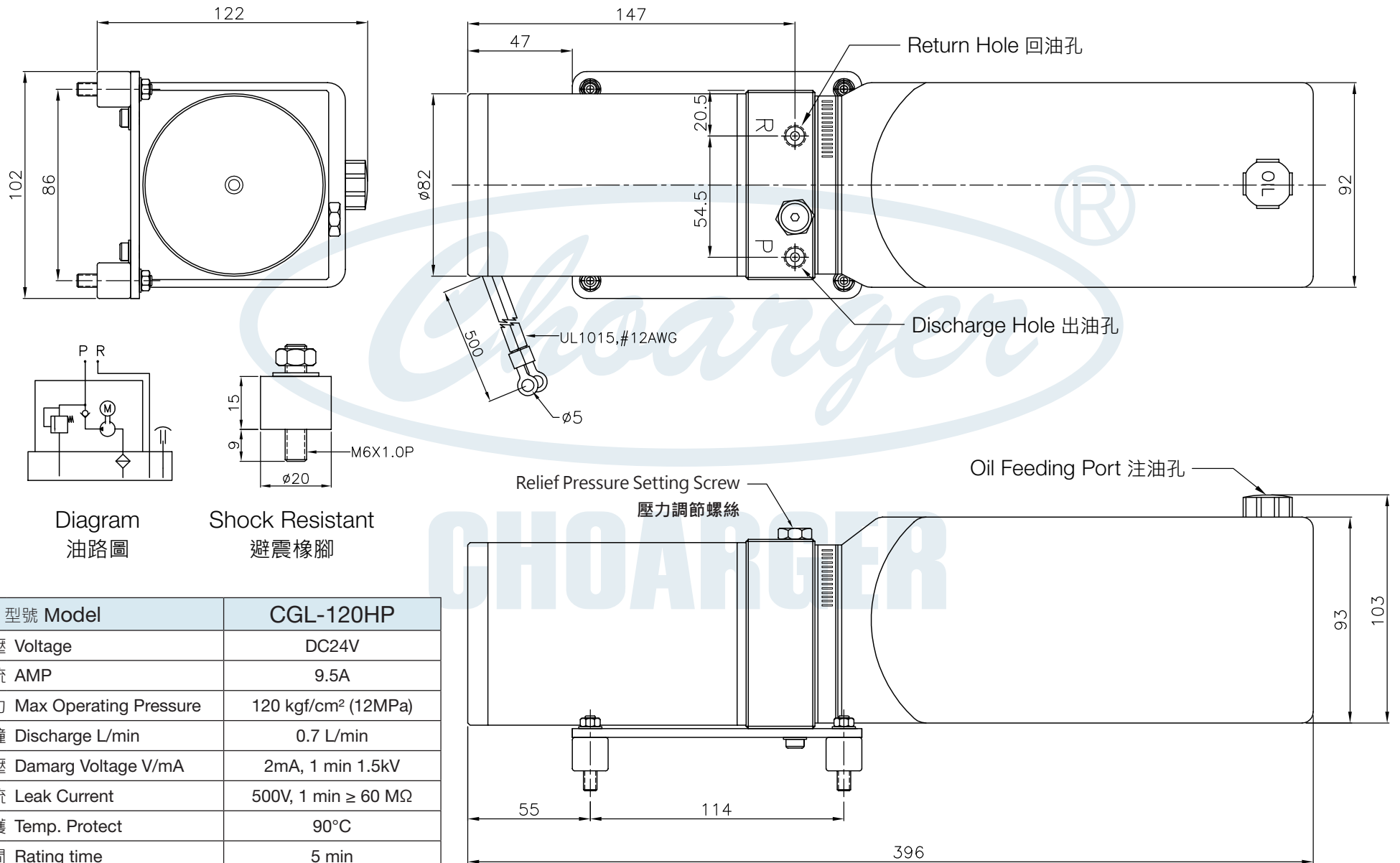

| 型號 Model | CGL-120HP |
|-----------------------------|---------------------------------|
| 電壓 Voltage | DC24V |
| 額定電流 AMP | 9.5A |
| 額定壓力 Max Operating Pressure | 120 kgf/cm ² (12MPa) |
| 出油量/每分鐘 Discharge L/min | 0.7 L/min |
| 耐電壓 Damarg Voltage V/mA | 2mA, 1 min 1.5kV |
| 洩漏電流 Leak Current | 500V, 1 min ≥ 60 MΩ |
| 溫度保護 Temp. Protect | 90°C |
| 額定時間 Rating time | 5 min |
| 接管規格 Threaded connection | PT 1/8" ; M8 × 1 |
| 重量 Weight | 4.1 kg |
| 油箱容量 Tank Capacity | 1.3 L |