

# CGL-120HP DC Motor Pumps

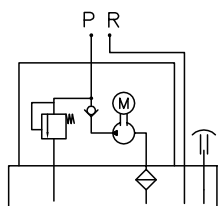
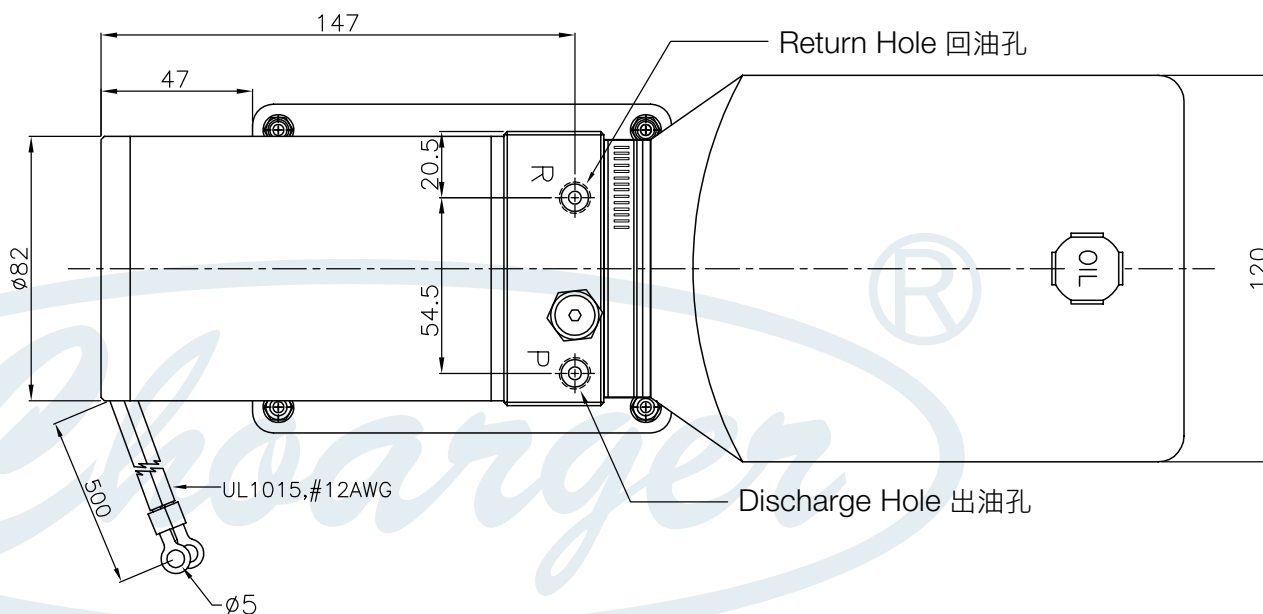
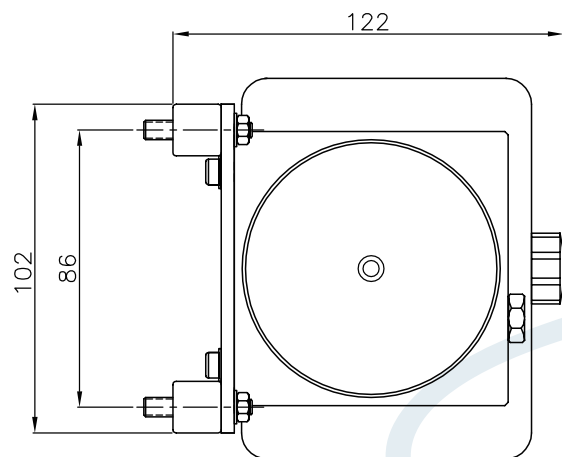
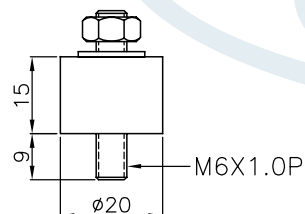

Diagram  
油路圖



Shock Resistant  
避震橡腳

型號 Model	CGL-120HP
電壓 Voltage	DC24V
額定電流 AMP	7.5A
額定壓力 Max Operating Pressure	120 kgf/cm <sup>2</sup> (12MPa)
出油量/每分鐘 Discharge L/min	0.5 L/min
耐電壓 Damarg Voltage V/mA	2mA, 1 min 1.5kV
洩漏電流 Leak Current	500V, 1 min $\geq 60 M\Omega$
溫度保護 Temp. Protect	90°C
額定時間 Rating time	5 min
接管規格 Threaded connection	PT 1/8" ; M8 x 1
重量 Weight	4.1 kg
油箱容量 Tank Capacity	1.0 L

