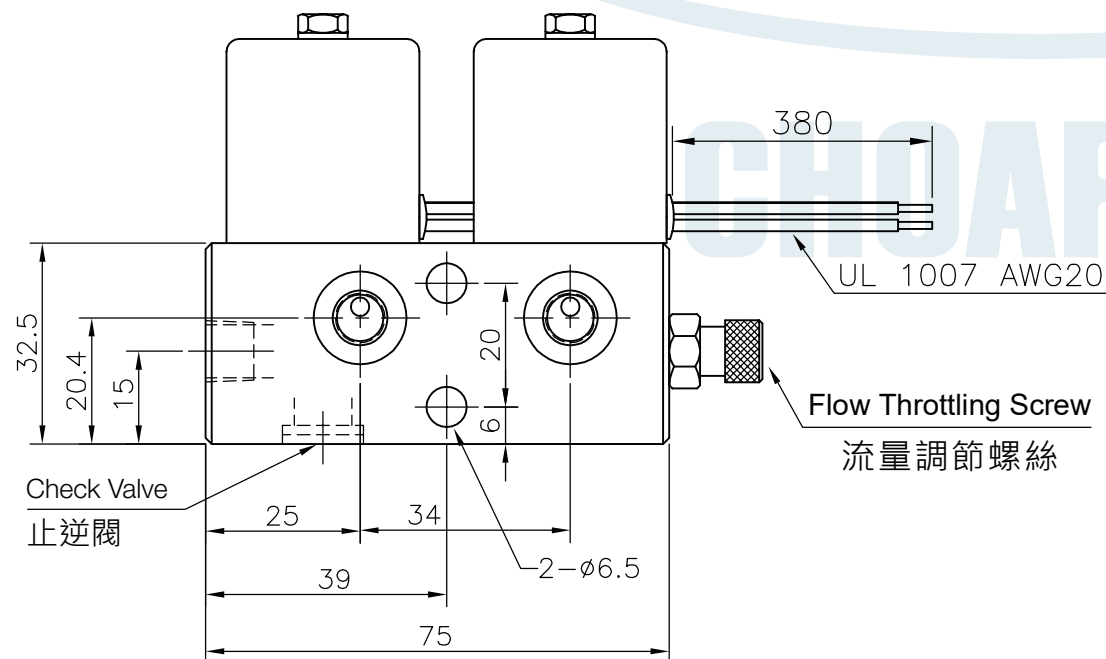

Diagram
油路圖



Function 功能	
• Check Valve	止逆閥
• Speed Adjust	速度調整

機種 Model	PR-1H
材質 Material	Brass 銅體
額定壓力 Max Operating Pressure	120 kgf/cm ² (12MPa)
接管規格 Threaded connection	PT" 1/8 ; M8 × 1
電壓 Voltage	AC24V/AC115V/AC230V DC12V / DC24V
額定時間 Rating time	10 min
重量 Weight	0.76 kg